

Instructions for use
—Type 1 Fix



Type 1 button-fix

The Button-fix concept is simple: the Fixes are attached to the back of one panel and the mating Buttons are attached to the other. Bring the panels together and slide until the Button-fixes 'click'.

The Type 1 Button-fix is moulded in durable, glass-filled nylon. It connects parallel panels and its strength has been verified by an independent test house. It can be configured in many different ways to best suit your application, either surface-mounted or rebated into the panel, and orientated for vertical or sideways assembly.

Visit the website for more information on the complete Button-fix range, including videos

of the Type 1 Button-fix in use. You can also obtain a new copy of these instructions from the website in the event of loss or in the event that Buttonfix modifies the instructions.

Buttonfix Limited retains the right to modify the instructions as it deems appropriate and the consumer is responsible for checking the website for the latest information.

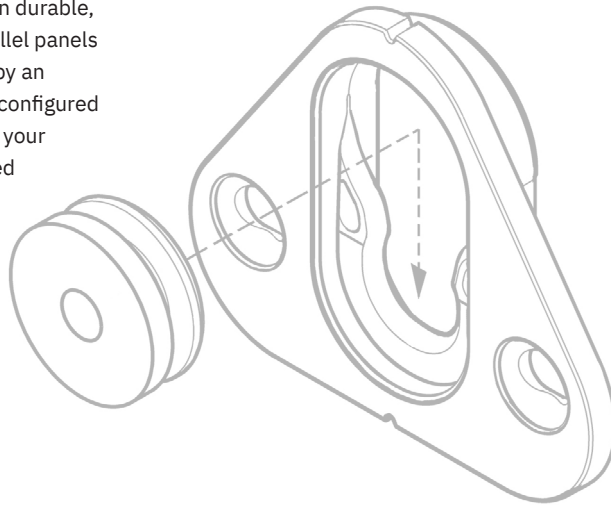

Warnings

—Button-fix is intended for furniture construction and interior fittings and is not intended, nor should it be used, for any other purpose.

—**WARNING:** Serious damage to property and severe bodily injury can result from (1) improper use, application or installation of the Button-fix or (2) use as part of improperly designed or constructed assemblies or materials.

—Provided that the screws and substrate are properly matched, and all other instructions complied with, independent tests showed that a vertical panel fixed with four Type 1 Fixes can support loads weighing up to a maximum of 200kg (440lbs). For critical applications it is essential to perform your own tests.

—Avoid any contact with aggressive solvents and cleaning products.

—It is not possible for Buttonfix to warn the consumer about every possible danger related to use of the Button-fix and the consumer must use his or her own good judgment when installing and using the Button-fix.

The button

There are two Buttons to suit different screw types. These are colour-coded lime green for Ø5mm countersunk wood screws, or orange for Ø6.2mm Varianta Euro screws (to fit Ø5mm pilot holes).

Check with your panel supplier which screw type is best for your application.

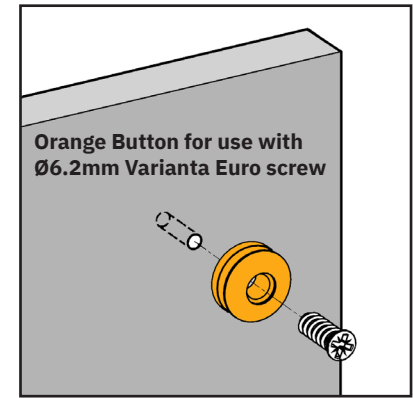
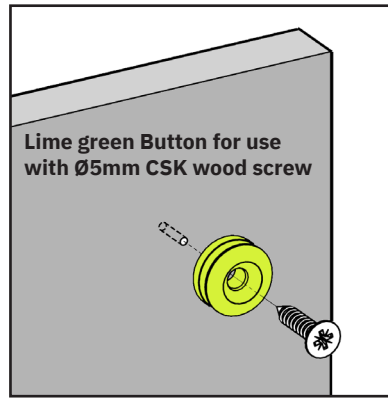

Button marker accessory

The Button marker accessory helps to mark out where to install the Buttons.

Once you have attached the Fix mouldings (see following pages), insert a marker into each one. Then position the second panel and press firmly. The markers will leave indents in the panel surface, which can be used as guides for drilling pilot holes for the Buttons.

Remove the markers, which can be re-used to mark out the next panel.

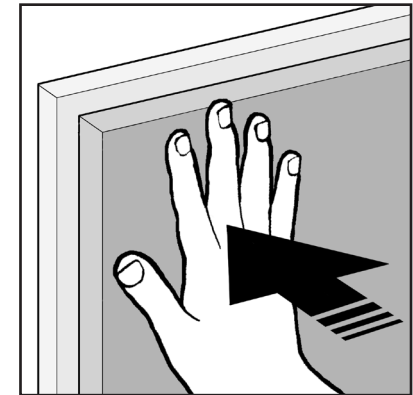
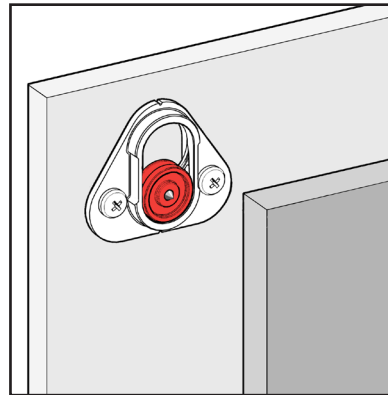

Surface-mounted fix

Surface mounting creates an 8mm gap between the two panels. The Fix can be configured in three options:

1. Button on removable panel

The Fix is attached to the background structure, pointing upwards as shown in the diagrams on the right.

In this configuration, the panels engage vertically and 15mm clearance is required above the removable panel.

2. Fix on removable panel

The Fix is attached to the removable panel, pointing downwards as shown in the diagrams on the right.

In this configuration, the panels engage vertically and 15mm clearance is required above the removable panel.

3. Sideways arrangement

The Fix is attached to either the background structure or the removable panel, pointing sideways as shown in the diagrams on the right.

In this configuration, the panels engage horizontally and 15mm clearance is required to the side of the removable panel.

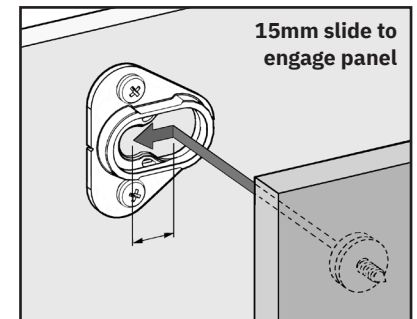
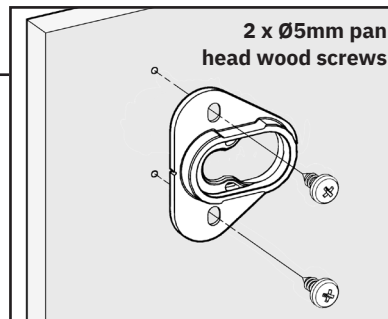
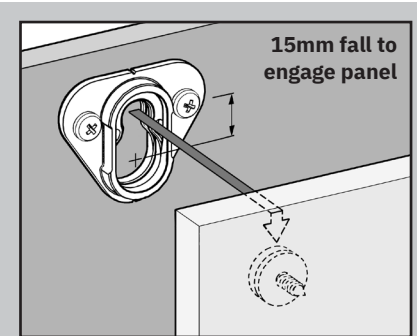
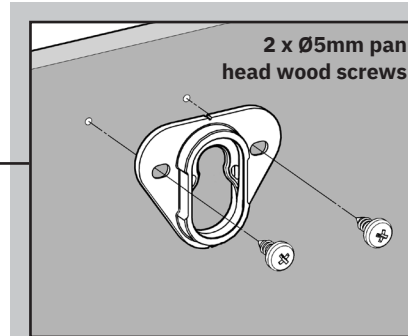
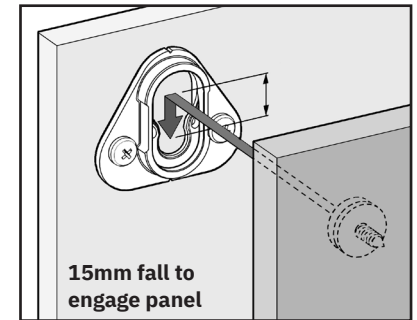
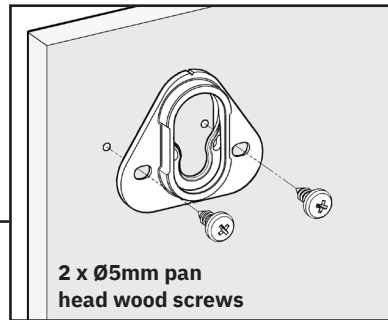

Rebated fix

Rebating the Fix creates a 3mm gap between the two panels. The Fix can be configured in three options:

1. Button on removable panel

The Fix is attached to the background structure, pointing upwards as shown in the diagrams on the right.

In this configuration, the panels engage vertically and 15mm clearance is required above the removable panel.

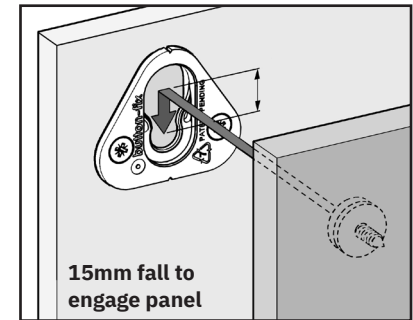
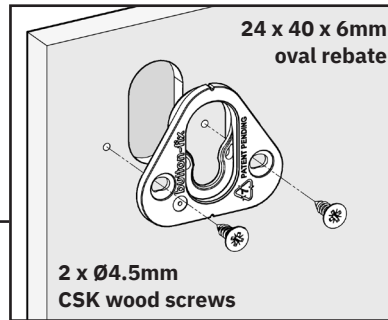

2. Fix on removable panel

The Fix is attached to the removable panel, pointing downwards as shown in the diagrams on the right.

In this configuration, the panels engage vertically and 15mm clearance is required above the removable panel.

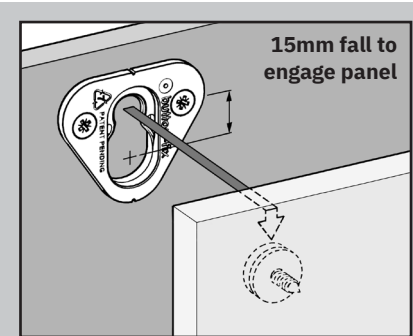
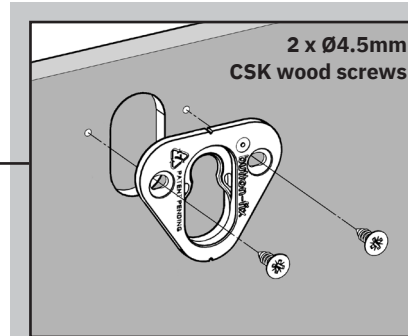

3. Sideways arrangement

The Fix is attached to either the background structure or the removable panel, pointing sideways as shown in the diagrams on the right.

In this configuration, the panels engage horizontally and 15mm clearance is required to the side of the removable panel.

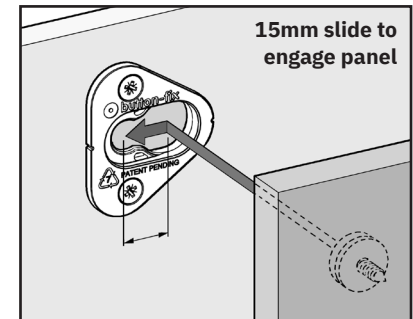
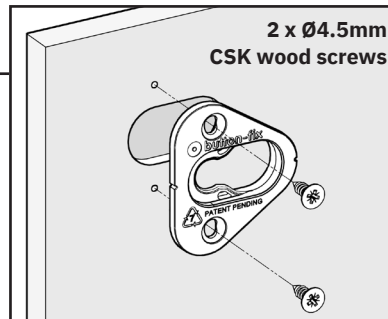

A useful tip

When several Button-fixes are used on a panel, or if you require the panel to be easily removable, first try spraying the fixes with a PTFE or Silicone based lubricant spray.

The strength of the click-fit can be further reduced by adapting some (but not all) the Fix mouldings by snapping off the ears with needle-nosed pliers, as shown in the diagram on the right.

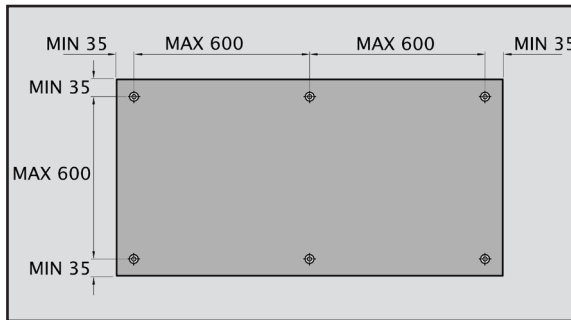
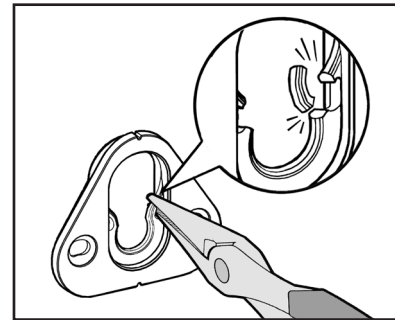

Suggested layout

As an approximate guide, we suggest that Button-fix centres are no greater than 600mm apart and no closer than 35mm to the edge of the panel.

Always remember to allow at least 15mm clearance for the removable panel to disengage.

Router jig accessory

A router jig can be ordered separately for accurately machining the rebates for the Fixes, described on the previous page.

The jig is designed for use with a metric 12mm cutter and 16mm guide bush. Read the separate instructions supplied with the accessory before use.

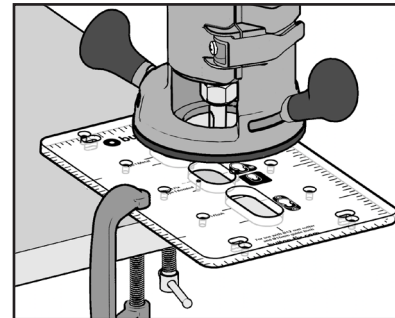

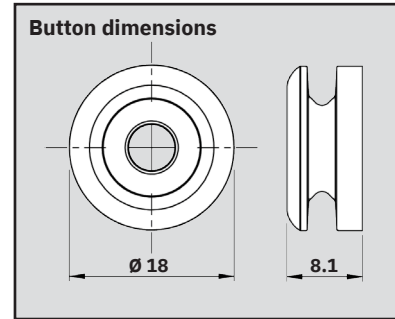
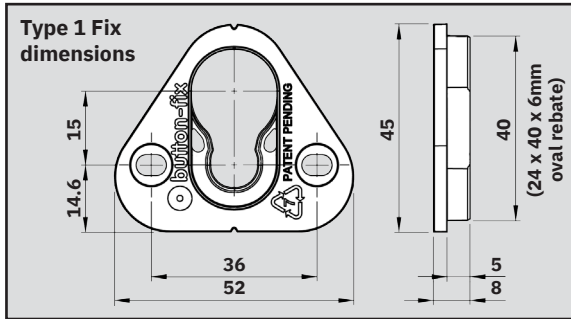

Manufactured in the UK

**Buttonfix Limited
Unit A, 1 Britton Street
London, EC1M 5NW**

T: +44 (0)20 8150 7190

E: info@button-fix.com



button-fix.com